

Heathkit of the Month #89:  
by Bob Eckweiler, AF6C



## ELECTRONIC TEST EQUIPMENT

### Heathkit O-9 through O-12 Oscilloscopes.

#### Introduction:

In the first of this series of articles four Heathkit oscilloscopes, the O-1 through O-4, were discussed. In second article the fifth through eighth Heathkit oscilloscopes, the O-5 through O-8, were discussed<sup>1</sup>. This third article discusses the last of the twelve 'O' series oscilloscopes, the O-9 through O-12.

The O-1 through O-6 sold for \$39.50; the O-7 sold for \$43.50, up 10%. The scope performance was improving with each new model and the price was also beginning to increase significantly. The O-8 price, increased almost 37% to \$59.50, and the the O-9 through O-12 sold in the \$65 to \$70 range. To meet the need of lower priced scopes, Heathkit started to release lower-performance ones starting in September 1954. These include the 3" OL-1 (\$29.50), and the 5" OM-1 through OM-3. (\$39.50 but later increased to \$49.50, \$42.50, \$39.95 respectively). Heathkit also produced a couple of higher performance and higher priced oscilloscopes, the 'Research' OR-1 oscilloscope and the 'Professional' OP-1 Oscilloscope. These boasted of a higher performance CRT, the 5ADP2, as well as true DC



**Figure 1:** The last of the Heathkit O-series scopes, the O-12. Photo by Chuck Penson - WA7ZZE

coupling, a sign of an advanced scope. They sold for \$119.95 and \$179.95 respectively.

A schematic and parts list are available online for the O-9 through O-12 (See note 5).

Heathkit introduced the O-9 to replace the O-8 in September of 1953. It remained in production until replaced by the O-10 in September one year later.

The O-10 was released in September of 1954 for \$69.50. Since the O-5, Heathkit had been releasing new scopes on a yearly basis in September. However, the O-10 through O-12 were each kept in production for more than one year.

Here is a link to the index of Heathkit of the Month (HotM) articles:

[http://www.w6ze.org/Heathkit/Heathkit\\_Index.html](http://www.w6ze.org/Heathkit/Heathkit_Index.html)

<sup>1</sup> Notes appear at the end of the article

The O-11 was released in September of 1956, giving the O-10 a production run of two full years. The O-11 also sold for \$69.50 and stayed in production for 18 months when it was replaced with the O-12.

The final Heathkit O-series oscilloscope, the O-12 (See **Figure 1**) was first advertised in *Radio TV News* in May of 1958. It came with little fanfare; no ‘New’ banner, not even any change in the ad description occurred. The only change was the O-11 was replaced with O-12 at the bottom, and the price was reduced from \$69.50 to \$64.95. The OM-2 was updated to the OM-3 with the same subtlety, and also included a downward price change from \$42.50 to \$39.95.

By late 1960 *Radio News*<sup>2</sup> had become *Electronic World* and the Heathkit advertising changed focus from test equipment to audio, amateur and home products. The newly introduced RF-1 RF Signal Generator, FMO-1 FM Test Oscillator and TT-1 Tube Tester were the only test equipment advertised from January through October. In 1960 no Heathkit ads for oscilloscopes were found in *Electronic World* until November of 1960 when “2 new scopes...” were introduced, the \$76.95 IO-30 which replaced the O-12. and the all-new \$79.95 IO-10 DC 3” scope.

**The O-9 Through O-12 scopes:**

The last four ‘O’-series scopes use a 5UP1 CRT. Heathkit’s O-9 advertising emphasizes that this CRT, made by RCA<sup>3</sup>, is not surplus, but doesn’t have a post deflection accelerator electrode like the O-8. Still, it is a CRT with the benefits of modern design at the time.

Also, starting with the O-9, the scopes feature voltage regulation. In the O-9 this is done with an 0D3 gas regulator tube to keep the important B+ voltages constant. But for the later O-10 through O-12 a newer circuit

adjusts the B+ voltages to respond to changes in the unregulated HV CRT voltage, and keeps the CRT trace constant with changes in line voltage.

Heathkit continued to update the sweep and sync circuits The O-9 through O-12 scopes allow syncing the sweep to the AC line frequency. It also has line frequency sweep. Note that this is not a linear sweep, but a sinusoidal sweep with no blanking.

**Table I** shows the tube lineup for the O-9 through O-12 scopes. While some of the tubes remain the same between models, oth-



**Figure 2:** Heathkit O-9 Oscilloscope; last of the Late Pre-Classic style scopes. Photo by Keith Greenhalgh.

O-9 to O-12 Tube Lineup						
#	Function	O-9	O-10	O-11	O-12	
1.	B+ Rectifier	5Y3	6X4	6X4	6X4	Dual Diode FW
2.	HV Rectifier	5Y3 <sup>1</sup>	1V2 <sup>2</sup>	1V2 <sup>2</sup>	1V2 <sup>2</sup>	1 Parallel diodes 2 HV Rectifier
3.	Voltage Regulation	0D3	6C4	6C4	6C4	See text
4.	Vertical Input Buffer	6AB4	6AB4	6AB4	6AB4	Triode
5.	Vertical Preamplifier #1	½ 12AT7 <sup>3</sup>	½ 6BQ7 <sup>3</sup>	½ 6AN8 <sup>3</sup>	½ 6AN8 <sup>3</sup>	<sup>3</sup> triode section
6.	Vertical Preamplifier #2	½ 12AT7 <sup>3</sup>	½ 6BQ7 <sup>3</sup>	½ 6AN8 <sup>4</sup>	½ 6AN8 <sup>4</sup>	<sup>4</sup> pentode section
7.	Vertical Phase Splitter	6C4	none	none	none	triode
8.	Vertical Deflection Amplifier	½ 12AT7	½ 12BH7	½ 12BH7	½ 12BH7	dual triode
9.	Vertical Deflection Amplifier	½ 12AT7	½ 12BH7	½ 12BH7	½ 12BH7	dual triode
10.	Horizontal Phase Splitter	½ 12AU7	none	none	none	triode
11.	Horizontal Input Buffer	none	½ 12AU7	½ 12AU7	½ 12AU7	dual triode
12.	Horizontal Amplifier	none	½ 12AU7	½ 12AU7	½ 12AU7	dual triode
13.	Horizontal Deflection Amplifier	½ 12AT7	½ 12AU7	½ 12AU7	½ 12AU7	} 12AT7 dual triode 12AU7 dual triode
14.	Horizontal Deflection Amplifier	½ 12AT7	½ 12AU7	½ 12AU7	½ 12AU7	
15.	Blanking Amplifier	½ 12AU7	½ 12AT7	½ 12AU7	½ 12AU7	triode section
16.	Sweep Multivibrator	½ 12AT7 <sup>5</sup>	6CB6 <sup>6</sup>	6DT6 <sup>6</sup>	½ 6J6 <sup>5</sup>	<sup>5</sup> triode section <sup>6</sup> pentode
17.	Sweep Multivibrator	½ 12AT7	½ 12AT7	½ 12AU7	½ 12AU7	triode section
18.	Sync Buffer	none	none	none	½ 6J6	triode section
19.	Cathode Ray Tube	5UP1	5UP1	5UP1	5UP1	RCA Mfr.
<b>Total Tubes:</b>		<b>11</b>	<b>11</b>	<b>11</b>	<b>11</b>	
<b>Total Tube Sections:</b>		<b>18</b>	<b>17</b>	<b>17</b>	<b>18</b>	

Table I

ers change either to improve performance or possibly due to economic considerations.

The following sections contain some circuit discussion. However since the previous two articles cover the circuits in detail, the focus here will be on changes made in each scope.

**The Heathkit O-9 Oscilloscope:**

The O-9 is a nice update to the O-8. A new 1V output replaces the 60 CY. TEST binding post. It has a 1V peak-to-peak output, derived from the filament voltage, that can be calibrated by an internal potentiometer. The O-8 is also the first of the 'O'-series scopes to have retrace blanking, since the crude version on the O-1. Due to the new line sweep

and sync capability, the front panel layout has changed in places.

**O-9 Front Panel:**

The O-9 front panel (refer to Figure 2) is similar to the O-8. The four controls around the CRT remain unchanged. Clockwise from the upper left they are: **INTEN.**, **FOCUS**, **HORIZONTAL CENTERING** and **VERTICAL CENTERING**. Also the row directly below the CRT remains identical except for the sweep frequency selector ranges; left to right they are: **VERT. GAIN**, **FREQ. SELECTOR** and **HOR. GAIN**. The next row down left to right are the **VERT. INPUT** attenuator, the **FREQ. VERIER** and the new line sweep **PHASE** control.

The next lower row is changed and controls are staggered vertically along the row to accommodate two new control locations that replace two of the slide-switches. This next row and the one below it, from left to right, are: The **VERT. INPUT** binding post, with its associated **GND.** below it; The **SYNCHRONIZING** control, which used to be where the **PHASE** control is now, and below it the **EXT.** sync binding post; a red jewel pilot lamp , and below it the power **OFF - ON** slide-switch; the new **HOR. SELECTOR** 5-position rotary switch and below that the **1V** calibration binding post; and finally the **HOR. INPUT** binding post and below that the associated **GND** post. The five positions of the **HOR. SELECTOR** switch, in clockwise direction are: **EXT. SWEEP**, **LINE SWEEP**, and three internal **SWEEP SYNC.** positions: **LINE**, **INT.** and **EXT.**

### The O-9 Circuit Description:

There are seven discussion points in the O-9 through O-12 oscilloscope circuits; the B+ and HV power supplies, the vertical amplifier, the horizontal amplifier, the sweep and sync circuits and the blanking amplifier.

### O-9 B+ Power Supply:

A new power transformer is used in the O-9. It is similar in lead color-coding and voltage, but has higher current output in the 700 VAC B+ secondary. The B+ power supply has four voltage outputs, the highest being around 400 volts. An 0D3 volt gas regulator tube provides 150 volts and two other voltages that are tapped off and filtered to drive the lower voltage circuits. The vertical buffer is isolated using one of these voltages; it is not isolated in the O-8. The O-9 uses four 20  $\mu$ f capacitors in a can, while the O-8 uses two 20  $\mu$ f and two 10  $\mu$ f for B+ filtering.

### O-9 HV Power Supply:

Since the CRT changed, the resistor voltage divider chain to supply the correct CRT volt-

ages has also changed. Other than that and more HV power supply filtering, the circuit is quite similar to the O-8.

### O-9 Vertical Amplifier:

The O-8 6J5 octal tube vertical input buffer has been replaced with a miniature 6AB4 7-pin triode. The three stage attenuator has not changed except for one resistor to compensate for the bias circuit required for the new tube.

The vertical amplifier and driver are similar to the O-8 but include significant component value changes that increase frequency response. The O-9 doubles the O-8 high frequency response at the -2 db point to 2 mc, (3 mc at -6 db).

### O-9 Horizontal Amplifier:

The horizontal amplifier phase splitter is changed from a 6J5 octal tube to a section of a miniature 9-pin 12AU7 dual-triode. The other section is used as the blanking amplifier. Other than that, and a few changes in component values, most notably larger coupling capacitors, and cathode resistors, the circuit is the same as the O-8.

### O-9 Sweep Oscillator:

The sweep circuit is driven from the highest B+ voltage as this allows better sweep linearity. The only change to the sweep generator is an increase in the cathode resistor, perhaps to raise sweep to a more linear portion of the RC charging curve. The sweep ranges remain the same as the O-8.

### O-9 Sync. Circuit:

The sync circuit is identical to the O-8. Instead of using a slide switch to select  $\pm$  sync, the identical function is inserted in the **HOR. SELECTOR** switch. In the **EXT. SWEEP**, and **LINE SWEEP** positions sync is not connected. In the first of the three **SWEEP SYNC** positions some of the filament voltage is connect-

ed to the sync line, and the last two positions, INT. and EXT. imitate the O-8's slide switch.

**O-9 Blanking Circuit:**

A blanking circuit turns off the CRT electron beam while the trace is moving rapidly back from the right side of the screen to the left side. Except for an early attempt with the O-1, Heathkit relied on the rapid movement of the trace back to the left to create such a dim trace that it was acceptable. In most cases it was. In the O-9 Heathkit dedicated the triode section of a 12AU7 tube to turn on during the blanking portion and apply a negative voltage pulse to grid-one of the CRT via the intensity modulation input to turn off the trace.

**O-9 Construction:**

Heathkit was continually trying to reduce costs of their kits and at the same time simplify construction whenever they could. The O-9 is the first of the Heathkit oscilloscopes that utilizes a prefabricated wiring harness to simplify construction. While probably more expensive for Heathkit, it offered easier and faster construction and reduced mistakes during assembly.

**The Heathkit O-10 Oscilloscope:**

The O-10 (**Figure 3**) was introduced in September of 1954 with the new Classic I style<sup>4</sup> with a dark gray front panel, white lettering and a slightly lighter gray cabinet.

The O-10 has many changes from the O-9. It is the first O-series oscilloscope to use printed circuit boards, and two of them no less. The lower cost OL-1 and OM-1 scopes, introduced the same month, also use circuit boards, though only one in each. And the OL-1 and OM-1 used the same printed circuit board, though some of the component values are different. The printed circuit board made construction easier and Heathkit's manufac-



**Figure 3:** Heathkit O-10 Oscilloscope; the last of the Late Pre-Classic style scopes. Photo by Chuck Penson.

turing costs less. Circuit boards were inexpensive to manufacture in moderate quantities, and the reduction in the cost of chassis machining, mounting hardware, terminal strips, and even some components helped Heathkit keep prices down. The increased ease of construction, and consistent wiring layout resulting in stability between units built, made more complicated kits possible without added difficulty for the builder. Heathkit appeared focused on making their kits easier to assemble and less likely to need to be returned for repair, which probably was a big expense for them.

Besides printed circuit boards, the O-10 also was the first Heathkit scope that used all miniature tubes (excluding the CRT). The three remaining octal tubes of the O-9, the two 5Y3 rectifiers and the OD3 VR tube no longer were used.

Another feature of the O-10 is a new voltage regulation circuit. Instead of using a VR tube, the O-10 measures the CRT high voltage and adjusts the B+ voltages to correct the trace deflection when the CRT acceleration voltage changes with line voltage.

### **O-10 Front Panel:**

The layout of the O-10 front panel appears almost identical to the O-9, color scheme excepted. The obvious change is the OFF - ON slide switch is gone. The fully CCW position of the INTENSity control on the upper left is now marked **A.C. OFF**. The pilot light remains where it is on the O-9.

There are also many less noticeable changes: The **FREQ. SELECTOR** switch is now marked **HOR. / FREQ. SELECTOR** with two added positions, **EXT. INPUT** and **LINE SWEEP**. The **SYNCHRONIZING** control is now called **SYNC AMPLITUDE** and it no longer is divided with negative sync to the left of center and positive sync to the right. The **HOR. SELECTOR** is now named **SYNC. SELECTOR**, and gone are the **EXT. INPUT** and **LINE SWEEP** positions; the remaining three positions that were under **SWEEP SYNC** are now four positions: **-INT.**, **+INT.**, **LINE** and **EXT. SYNC**. The last change is the **1-V P-P** and the **EXT. SYNC**. binding posts locations have been swapped.

### **The O-10 Circuit Description:**

The circuitry of the O-10 shares little with the previous O-series scopes, though the functions remain the same. Heathkit was striving for better vertical bandwidth and

improved linearity of the sweep circuit. The O-10 vertical and horizontal amplifiers, except for some minor component changes, remains the same for the O-11 and O-12. The O-10 sweep circuit is described in the manual as *“utilizing Heath sweep circuit. (Patent applied for.)”*. Still, the circuit was further refined in the O-11 and O-12.

### **O-10 B+ Power Supply:**

In order to use miniature rectifier tubes the power transformer was changed. The two 5V filament windings for the 5Y3GT tubes are gone. The new seven-pin 6X4 rectifier tube has a 6.3 V heater. The 6.3V winding received a center-tap which is connected to ground; this is possibly to reduce stray 60 cps. radiation within the scope cabinet.

Voltage regulation is handled by a 6C4 triode. The grid is connected to the bottom of the CRT high-voltage chain. Should the high voltage increase, due among other reasons by the line voltage changing, the 6C4 grid goes more negative and the tube conducts less, raising the voltages on numerous circuits, increasing the vertical and horizontal gain countering the lower deflection that occurs when the acceleration voltage increases.

### **O-10 HV Power Supply:**

The 5Y3 rectifier is gone and a nine-pin single diode 1V2 high voltage rectifier tube, which easily handles the 1,200 VDC CRT voltage, replaces it. The new power transformer has a 0.62 V winding for the 1V2 tube filament. This winding is a few extra turns at the top of the high voltage winding.

The CRT voltage divider chain is the same as the O-9 except the **FOCUS** control is 1 M $\Omega$  (was 2 M $\Omega$ ) and a 15 K $\Omega$  resistor is added at the bottom of the chain to provide a tap for the voltage regulator circuit.

**O-10 Vertical Circuits:**

The vertical attenuator circuit was changed from two separate dividers for the x10 and x100 positions to a series divider that handles both. The buffer for the attenuator is also changed adding some feedback to enhance input impedance and high-end frequency response.

The output of the buffer is amplified by both sections of a 6BQ7A dual triode in cascade. Each amplifier uses a peaking coil to enhance the vertical response. These coils in effect raise the plate resistance at higher frequencies increasing the gain to compensate for tube loss. While Heath used peaking coils in the vertical driver, this is the first use in the pre-driver stages.

The use of peaking coils rule out the use of a phase-splitter for the driver stage. Thus, a new driver circuit that allows position control, synchronization taps and push-pull output was developed. This circuit continued to be used through the O-12 without modification.

Referring to **Figure 4**: The AC signal is coupled to the grid of V3A and then to V3B through the common 1.2KΩ cathode resistor. Since the voltage across this resistor remains nearly constant, when V3A draws more current less current flows through V3B. With the VERTICAL POSITION pot at center, the voltage on the two grids are the same (since no current is flowing, the drop across the 3.3 MΩ resistor is negligible). As the pot is moved the DC bias on the two tubes changes and one tube draws more current. The DC

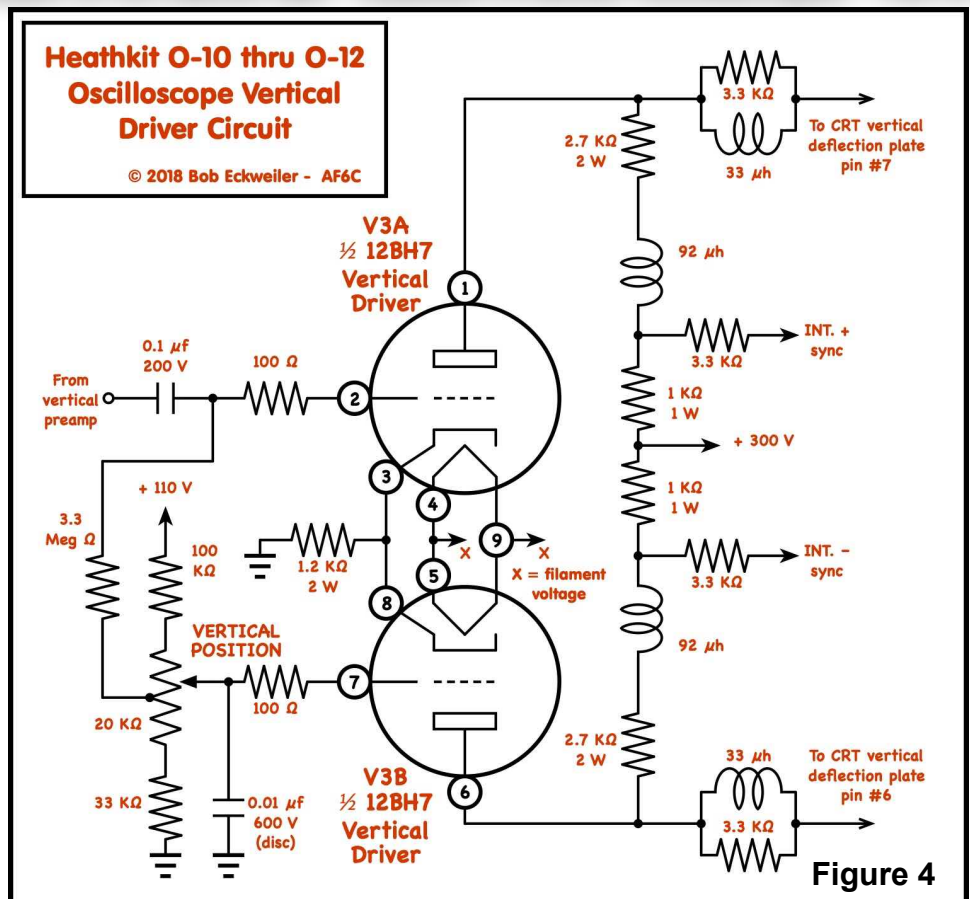

**Figure 4**

voltage on the vertical deflection plates differ and the trace is moves to a different vertical position on the screen. The 100 Ω resistors in the grid circuit are for parasitic suppression.

The plate supply is 300 VDC and the each plate circuit consists of 3.7 KΩ in series with 92 μh. the inductance increases the plate resistance at higher frequencies increasing gain as the tube losses mount, extending the high end frequency response. The driver plates are also coupled to the deflection plates through a coil shunted by a resistor. My guess is that this is to help cancel the wiring and deflection plate capacitance at the higher frequencies.

**O-10 Horizontal Amplifier Circuit:**

The O-10 horizontal amplifier/driver is a totally new circuit. It is based on the vertical circuit, without the need to have high gain and high frequency response. The O-10 has a

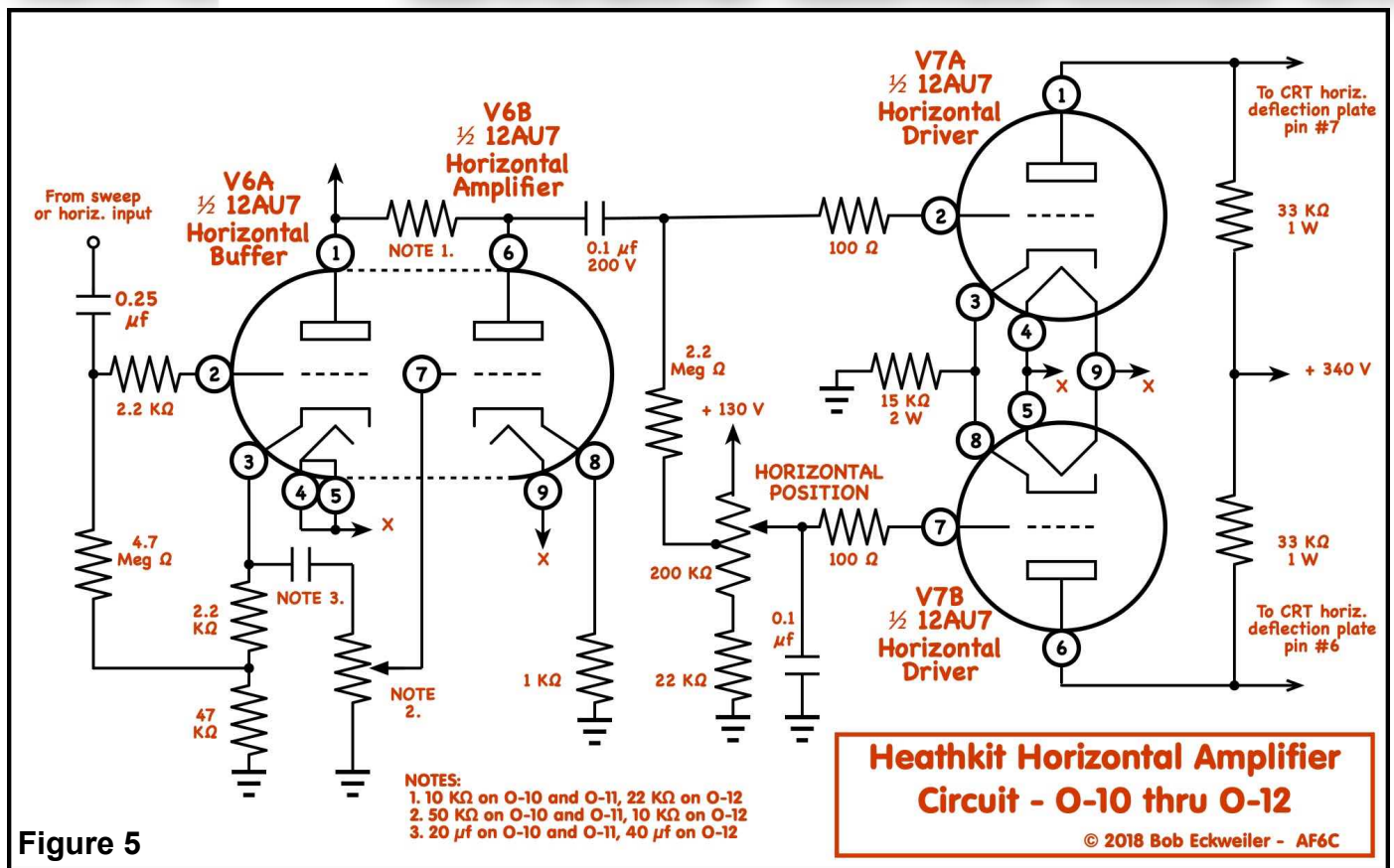

maximum gain of about 0.6 Vrms per inch of deflection and a frequency response up to about 500 kc. The new circuit is shown in **Figure 5**.

Two 12AU7 dual triodes are used in the horizontal circuits. The first stage acts as a cathode follower–buffer. It uses feedback from the cathode to the grid to increase the input impedance. This high impedance is needed due to the new sweep oscillator circuit. The saw-tooth sweep voltage is taken directly from the sweep capacitor.

The second half of the first 12AU7 is a simple voltage amplifier with a gain of about 10. It drives the second 12AU7 in basically the same circuit as the vertical driver circuit, but without the added components to increase frequency response. The actual components used are different than the vertical amplifier due to the difference in needed gain and the use of a 12AU7 instead of the higher power 12BH7.

**O-10 Sweep Circuit:**

Heath called its newly patented sweep circuit for the O-10 a “*recurrent type*”. In the O-10 it consists of a pentode and the triode section of a 12AT7. Heath never discussed its operation in their manuals. Here is the author’s take on it. See **Figure 6**:

Assume at the beginning (point ‘a’ on the Cx graph) that V4 is in cutoff and the timing capacitor Cx is discharged. The grid of V5A, thus is highly positive with respect to its cathode and current flows through the tube heavily, rapidly charging Cx. As Cx charges the cathode voltage of V5A climbs until it begins to turn off. The reduction in plate current causes the grid voltage of V4 to climb and it begins to turn on, driving V5A to shut down faster (point ‘b’). With V5A shut-down Cx begins to discharge through the FREQ. VERNIER control and its fixed series resistor. This is the ramp that is amplified



and fed to the horizontal deflection plates. As the voltage across Cx gets smaller current begins to flow in V5A driving the grid of V4 towards negative and turning it off, which increases the grid voltage, making V5A turn on even faster (point 'c'). With V5A off Cx begins charging again reaching the point where Cx is fully charged and V5A is ready to turn on again (point d). The resulting ramp from 'b' to 'c' is fed to the horizontal amplifier to move the trace from left to right at a

reasonably constant rate. The speed of the ramp is governed by the speed of discharge of Cx. Coarse adjustment is done by switching the capacitor Cx in approximately decade steps; the fine adjustment is done with the 7.5 MΩ frequency vernier control.

**O-10 Sync. Circuit:**

Heath seemed to be trying to continually improve the synchronization circuit. Improvements in the O-10 include separate plus and minus sync selection by a switch, instead of using half the center tapped sync level pot for positive and the other for negative sync. The AC line sync is now fixed, and the phase control only affects the horizontal line sweep. This allows syncing on different parts of the horizontal sweep. The sync signal is fed to the screen grid of the sweep circuit causing it to lock the sweep circuit to the sync signal when the sweep frequency or one of its harmonics is close to the sync signal.

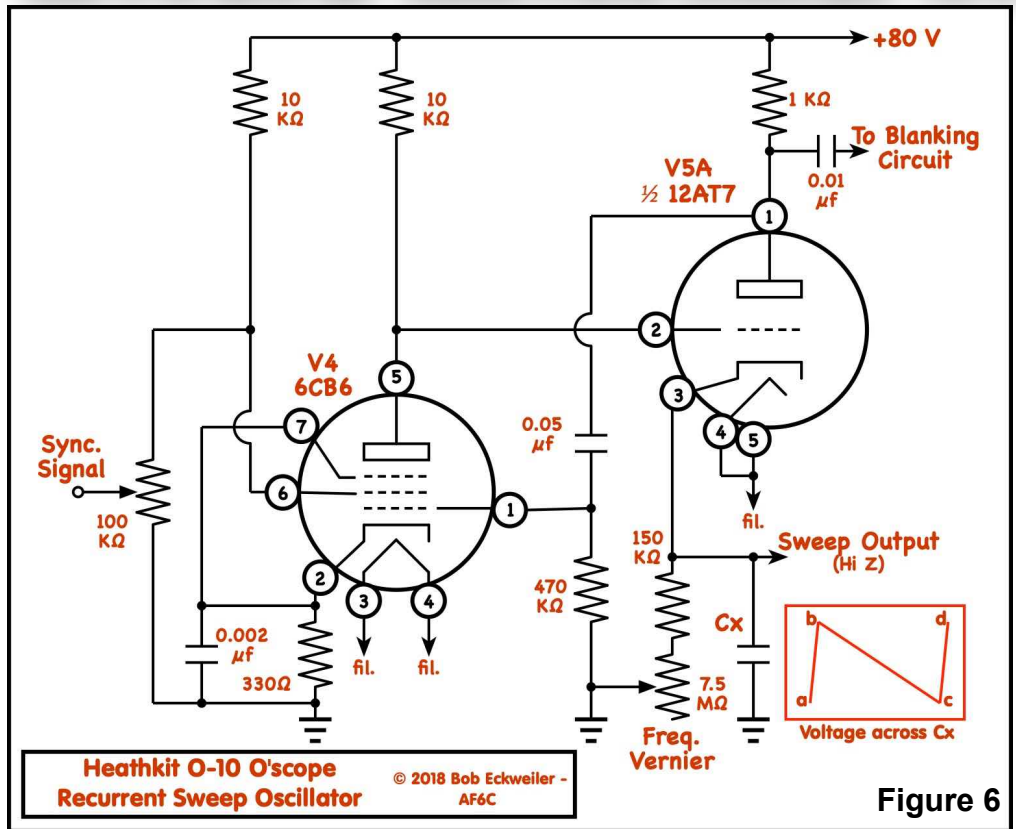

Figure 6

**O-10 Blanking Circuit:**

V5B (See full O-10 schematic online <sup>5</sup>) acts as a blanking amplifier. It is normally conducting. The cathode of the CRT is generally less negative than the first grid. As the voltage gets further apart less beam current flows until the CRT is cutoff. The blanking amplifier, V5B, is capacitively coupled to the plate of V5A. When V5A turns on (at 'a' and 'c' on the Cx voltage graph) a negative pulse is coupled to the grid V5B causing it to turn V5B off. The resulting positive pulse is capacitively coupled to the CRT cathode, making it more positive, cutting off the trace as it rapidly returns to the left of the screen. This is known as the retrace period.

**O-10 Comments:**

After nine previous scopes in the O-series, all viable instruments that found a lot of use by TV and radio repairmen, radio amateurs and electronic hobbyists, Heathkit was reaching a point where the O-series oscilloscope design

was close to the best kit scope that could be built for the price. Much of the O-10 circuit design continued to be used on the two final scopes in the series as well as the early IO-series until that series switched to solid-state circuitry.

### The Heathkit O-11 Oscilloscope:

After a two year run the O-10 was updated to the O-11 (**Figure 7**) in September of 1956. A lot of the circuitry remained the same or underwent minor changes. The O-11 sold for \$69.50 until April of 1958 when it was superseded with the O-12.

### O-11 Front Panel:

An examination of the O-11 front panel layout shows it to be identical to the O-10 with one simple exception; the pilot lamp lens is no longer a jeweled lens, instead it is a green plastic dome lens. Of course the model number was incremented to O-11 also.

### The O-11 Circuit Description:

There were only minor changes between the O-11 and its predecessor.

### O-11 Power Supplies:

No changes were spotted between the O-10 and O-11 HV nor B+ power supplies. The CRT divider chain remained unchanged as did the voltage regulator circuit, with the exception of the dropping resistor for the 100 V tap. It changed from 1.5 K $\Omega$  to 3.3 K $\Omega$ .

### O-11 Vertical Circuits:

There were some changes in the buffer/follower circuit. The preamplifier tube was changed from a 6BQ7A dual-triode to a 6AN8 triode/pentode. At the first vertical amplifier stage (V2A-6AN8 triode section) the plate resistor was increased from 2.2 K $\Omega$  to 2.4 K $\Omega$ , and the second stage V2B-6AN8 pentode section) the series plate inductor was decreased from 92 to 61  $\mu$ H and the parallel inductor to the driver was increased to 30  $\mu$ H. These were probably



**Figure 7:** Heathkit O-11 Oscilloscope. Except for the pilot lens and model # the front panel is identical to the O-10. Photo by Keith Greenhalgh.

done to enhance frequency response to make it more in-spec. The screen of the 6AN8 pentode is connected directly +100 V feeding the two preamplifier stages.

### O-11 Horizontal Amplifier Circuit:

There were no changes from the previous model. Refer to **Figure 5** for the O-11 horizontal circuit schematic.

### O-11 Sweep Circuit:

The sweep circuit changes to the O-11 are the 6CB6 (V4) tube has been replaced with a 6DT6 and the 12AT7 (V5) to a 12AU7. This results in a change to the V4 and V5A plate resistors and removal of the V4 cathode re-

sistor and its bypass capacitor. But the remainder of the circuit, its component values and operation remain unchanged as does its function. The reason for the (V4) tube change is discussed in the next section.

### **O-11 Sync. Circuit:**

The 6DT6 pentode is classified as having “two independent control grids”. In the O-10 the sync signal is coupled to the screen grid; while in the O-11 it is coupled directly to grid three (the second control grid) which is much more sensitive allowing syncing with a smaller signal.

Due to the higher sync. sensitivity Heath changed the SYNC. AMPLITUDE potentiometer from a linear-taper to an audio-taper. A linear-taper control reaches 50% of the full resistance at 50% rotation, while an audio-taper reaches about 10% of the full resistance at 50% rotation. This makes adjustment less critical for large sync signals even with the added sensitivity.

### **O-11 Blanking Circuit:**

Though V5B has been changed to a 12AU7, the circuit and components remain the same. This tube acts as a switch and is either on or off. The reason for the V5 tube change from a 12AT7 to a 12AU7 is not known. While the 12AT7 was used extensively in O-7 through O-9, only one was used in the O-10. Meanwhile the 12AU7 was being used more. Thus this change could have been for an economic reason and not an engineering reason.

### **The Heathkit O-12 Oscilloscope:**

In May of 1958 The O-12 appeared, replacing the O-11. The text from the April and May 1958 issues of *Radio News* are shown in **Figure 8**. The one significant change between the two scopes was not even mentioned: Heath doubled the sensitivity of the horizontal amplifier to 0.3 volts per inch. A new ad

appeared in the June issue with more detail, but no “NEW” banner. Perhaps it was an advertising deadline driving the May ad. Other changes Heathkit made was adding one resistor to the vertical amplifier and doing another redesign of the sync circuit.

### **O-12 Front Panel:**

The O-12 front panel appears identical to the O-11 except the model designation and one control. The SYNC. AMPLITUDE control has been renamed to the **EXT. SYNC. AMPLITUDE** control because the internal sync no longer needs a gain setting.

### **O-12 Power Supplies:**

No changes of consequence were found in the O-12 power supplies nor in the CRT chain.

### **O-12 Vertical Circuits:**

The only circuit note was a low value (220  $\Omega$ ) resistor added between the VERTICAL GAIN control and ground, setting a minimum gain.

### **O-12 Horizontal Amplifier Circuit:**

Two resistors and a capacitor were changed to double horizontal amplifier sensitivity from 0.6 volts per inch to 0.3 volts per inch. The note in **Figure 5** shows the changes.

### **O-12 Sweep Circuit:**

The 6DT6 vacuum tube (V4) has been replaced with a triode section of a 6J6 dual triode (now V4B). Operation of the sweep circuit continues basically unchanged.

### **O-12 Sync. Circuit:**

Heath engineers finally separated the sync amplification from the sweep oscillator. The other half of the 6J6 (V4A) is used as a sync amplifier. It also acts as a clipper allowing the scope to sync to waveforms from the vertical amplifier. Since there is no longer a need for a gain control for internal sync. that gain control has been renamed EXT. SYNC AMPLITUDE . The control remains at the same

**HEATHKIT "EXTRA DUTY" 5" OSCILLOSCOPE KIT**

This fine oscilloscope compares favorably to other scopes costing twice its price. It contains the extra performance so necessary for monochrome and color-TV servicing. Features push-pull horizontal and vertical output amplifiers, a 5UPI CRT, built in peak-to-peak calibration source, a fully compensated 3-position step-type input attenuator, retrace blanking, phasing control, and provision for Z-axis modulation. Vertical amplifier frequency response is within +1.5 and -5 db from 3 CPS to 5 MC. Response at 3.58 MC down only 2.2 db. Sensitivity is 0.025 volts RMS/inch at 1 kc. Sweep generator covers 20 CPS to 500 kc in five steps, five times the usual sweep obtained in other scopes through the use of the patented Heath sweep circuit. Etched-metal circuit boards reduce assembly time and minimize errors in assembly, and more importantly, permit a level of circuit stability never before achieved in an oscilloscope of this type. Shpg. Wt. 21 lbs.

MODEL O-11  
\$69.50

**HEATHKIT "EXTRA DUTY" 5" OSCILLOSCOPE KIT**

This fine oscilloscope compares favorably to other scopes costing twice its price. It contains the extra performance so necessary for monochrome and color-TV servicing. Features push-pull horizontal and vertical output amplifiers, a 5UPI CRT, built in peak-to-peak calibration source, a fully compensated 3-position step-type input attenuator, retrace blanking, phasing control, and provision for Z-axis modulation. Vertical amplifier frequency response is within +1.5 and -5 db from 3 CPS to 5 MC. Response at 3.58 MC down only 2.2 db. Sensitivity is 0.025 volts RMS/inch at 1 kc. Sweep generator covers 20 CPS to 500 kc in five steps, five times the usual sweep obtained in other scopes through the use of the patented Heath sweep circuit. Etched-metal circuit boards reduce assembly time and minimize errors in assembly, and more importantly, permit a level of circuit stability never before achieved in an oscilloscope of this type. Shpg. Wt. 21 lbs.

MODEL O-12  
\$64.95

**Figure 8:** On the left is the text from the April 1958 issue of Radio News advertising the O-11; ads with identical text had appeared in earlier issues. On the right is text from the May 1958 issue advertising the O-12. The ad has the identical text. only the model number and price have changed.

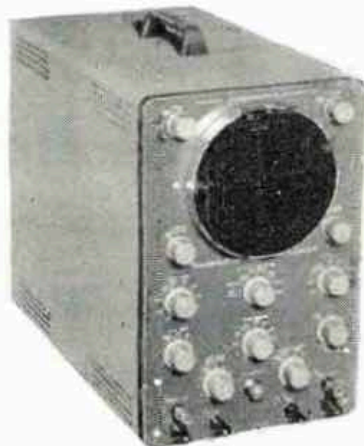

**Laboratory Performance At Less Than Utility Scope Price**

HEATHKIT O-12 \$64.95

**"EXTRA DUTY" 5" OSCILLOSCOPE KIT**

Top quality features at half the cost of ordinary equipment sum up the advantages of this popular kit. Critical observations in your laboratory or shop are handled easily, with clear, sharp pattern displays in every application. Vertical frequency response extends from 3 CPS to 5 mc +1.5 db -5 db without extra switching. Response is down only 2.2 db at 3.58 mc. The Heath patented sweep circuit functions effectively from 10 CPS to better than 500 kc in five steps, giving you 5 times the usual sweep obtained in other scopes. An automatic sync circuit with self-limiting cathode follower provides excellent linearity and lock-in characteristics. Extremely short retrace time and efficient blanking action. Both vertical and horizontal output amplifiers are push-pull and the scope incorporates a 1 V peak-to-peak calibrating source, step attenuated and frequency compensated vertical input, plastic molded capacitors and top quality parts throughout. The 11-tube circuit features a 5UPI cathode ray tube, and provision is made for Z-axis input for intensity modulation of the beam. Frequency response of the horizontal amplifier is within ±1 db from 1 CPS to 200 kc. Horizontal sensitivity is 0.3 volts RMS per inch. Construction is simplified through the use of two metal circuit boards and precut, cable wiring harness. Shpg. Wt. 22 lbs.

location on the front panel, but now only adjusts the level of an applied external sync signal. The internal sync signals are now coupled to the sweep oscillator by a common cathode resistor between the two triode sections of V4.

**The End of an Era:**

In 1960 the O-12 was replaced with a new scope series starting with the IO-30. The IO-30 features a heavier-duty power supply and two fixed sweep frequencies that can be preset and selected from the front panel. It also incorporates a short lived style that was a derivative of the Classic I style.

← **Figure 9:** This June 1958 ad shows more information than in May including the new horizontal sensitivity of 0.3 V/in and an increased shipping weight.

**Comments:**

This is the final article in the 'O' Series Heathkit scope article. These scopes are the first series of test equipment that helped make Heathkit well known as the leader in electronic kits for almost half a decade. Here are a few other pieces of information that might be of interest.

Transformers are one of the more expensive pieces of a scope. Originally Heath started out with a heavy WWII surplus transformer. The O-2 transformer was a lot smaller and lighter, but still believed to be war surplus. The O-3 through O-5 used the same transformer, but it was changed for the O-6. Between the O-6 and the O-7 Heath changed its part numbering scheme, so it's hard to say whether they are the same or not. Looking at the schematic, they have identical windings but the O-6 schematic does not give voltages nor currents for the transformer, while the O-7 does. Heath again changed the power transformer for the O-8 and again for the O-9. It was changed again for the O-10, but this transformer continued to be used by the O-11 and the O-12. **Table II** shows the part numbers of the 'O'-series oscilloscopes.

Heath continued to strive to increase the frequency response of these scopes. Probably the biggest reason was for television servicing. A frequency of importance was 4.5 mc so to have a frequency of 5 mc was ideal. Heath reached it, but with some loss with the O-10,

<b>O-SERIES POWER TRANSFORMERS</b>			
O-1	Surplus	O-7	54-1
O-2	Smaller surplus	O-8	54-18
O-3	O-72*	O-9	54-19
O-4	O-72*	O-10	54-26
O-5	O-72*	O-11	54-26
O-6	O-125*	O-12	54-26

\* Early Heathkit parts numbering system

**Table II**

<b><u>SWEEP FREQUENCY SELECTOR RANGES</u></b>			
	<b>O-9<sup>a</sup></b>	<b>O-10</b>	<b>O-11 / O-12</b>
<b>1.</b>	<b>15 - 180</b>	<b>60 cps - Line</b>	<b>60 ~ - Line</b>
<b>2.</b>	<b>180 - 1800</b>	<b>20 - 100</b>	<b>10 - 100</b>
<b>3.</b>	<b>1800 - 12 kc</b>	<b>100 - 1000</b>	<b>100 - 1000</b>
<b>4.</b>	<b>12 kc - 100 kc</b>	<b>1000 - 10 kc</b>	<b>1000 - 10 kc</b>
<b>5.</b>	<b>n/a</b>	<b>10 kc - 100 kc</b>	<b>10 kc - 100 kc</b>
<b>6.</b>	<b>n/a</b>	<b>100 kc - 500 kc</b>	<b>100 kc - 500 kc</b>

a. Same sweep ranges as the O-8  
kc = kilocycles, all others are cps (cycles per second)

**Table III**

not that the earlier scopes were totally blind at that frequency. The last three scopes are specified at being 5 db down at 5 mc (1 kc reference). this means that if the gain is set so a 1 kc 1 volt signal produces a 2" deflection, then a 5 mc 1 volt signal will produce a deflection of about 1-1/4 inches.

With the advent of color television another frequency became important. A scope needed to see the color-burst frequency of 3.58 mc. Thus, starting in 1954, Heath added a spec for the vertical response at that frequency. This was specified at -1.5 db on the O-10, which might have been a bit optimistic because it was lowered to -2.2 db on the two later scopes. Against the same reference as above -2.2 db means a 3.58 mc signal of 2 volts would produce a deflection slightly more than 1-1/2 inches.

Heath also spent a lot of effort improving the sweep frequency range. Table III show the ranges as they appear on the front of each of the last four model scopes. These numbers didn't always jibe with the specifications given in ads and possibly in the manuals. Any little unspecified added range at the ends of the fine sweep control should be thought of as a feature.

Specification	O-9	O-10	O-11	O-12
Announced Date: Discontinued Date:	September 1953 August 1954	September 1954 August 1956	September 1956 April 1958	May 1958 November 1960
<b>VERTICAL AMPLIFIER</b>	Push - Pull	Push - Pull	Push - Pull	Push - Pull
Input Impedance	2 MΩ / 47 μpf (x1) 2 MΩ / 35 μpf (x10/x100)	2.9 MΩ / 21 μpf (x1) 3.4 MΩ / 12 μpf (x10/x100)	2.9 MΩ / 21 μpf (x1) 3.4 MΩ / 12 μpf (x10/x100)	2.9 MΩ / 21 μpf (x1) 3.4 MΩ / 12 μpf (x10/x100)
Sensitivity (volts per inch)	0.025 Vrms @ 1 kc	0.025 Vrms @ 1 kc	0.025 Vrms @ 1 kc	0.025 Vrms @ 1 kc
Freq. Response.	± 2 db 10 cps 2 mc ± 6 db 5 cps 3 mc	± 1 db 6 cps 2.5 mc +2 to -5 db 2 cps 5 mc -1.5 db @ 3.58 mc	± 1 db 8 cps 2.5 mc +1.5 to -5 db 3 cps 5 mc -2.2 db @ 3.58 mc	± 1 db 8 cps 2.5 mc +1.5 to -5 db 3 cps 5 mc -2.2 db @ 3.58 mc
Attenuator	x1 / x10 / x100	x1 / x10 / x100	x1 / x10 / x100	x1 / x10 / x100
<b>HORIZONTAL AMPLIFIER</b>	Push - Pull	Push - Pull	Push - Pull	Push - Pull
Input Impedance	1 MΩ	30 MΩ / 31 μpf	30 MΩ / 31 μpf	30 MΩ / 31 μpf
Sensitivity (volts per inch)	0.6 Vrms @ 1kc	0.6 Vrms @ 1kc	0.6 Vrms @ 1kc	0.3 Vrms @ 1kc
Freq. Response H Amp.	± 6 db 10 cps 500 cps	± 1 db 1 cps to 200 kc ± 3 db 1 cps to 400 kc	± 1 db 1 cps to 200 kc ± 3 db 1 cps to 400 kc	± 1 db 1 cps to 200 kc ± 3 db 1 cps to 400 kc
<b>SWEEP CIRCUIT</b>	Multivibrator	Recurrent Type	Recurrent Type	Recurrent Type
Horizontal Sweep Range	10 cps to 50 kc	20 cps to 500 kc	20 cps to 500 kc	10 cps to 500 kc
Range Switch Positions	4	5 + Line	5 + Line	5 + Line
60-cycle Test Voltage Post	Yes, 1 V p to p	Yes, 1 V p to p	Yes, 1 V p to p	Yes, 1 V p to p
<b>SYNCHRONIZATION</b>	from phase splitter	From Vert. amp plate	From Vert. amp plate	From Vert. amp plate
External Input	± Int., ± Ext, Line	± Int., ± Ext, Line	± Int., ± Ext, Line	± Int., ± Ext, Line
Power - 50/60 cps	105/120 VAC 70 W	105/125 VAC 80 W	105/125 VAC 70 W	105/125 VAC 70 W
Fuse	One @ 1½ amp (internal)	None	One @ 1½ amp (internal)	One @ 1½ amp (internal)
Electrostatic CRT Shield	No	No	No	No
Astigmatism (spot) Control	Yes	Yes	Yes	Yes
Direct Input to CRT Deflection Plates	Yes	Accessible - See Text	Accessible - See Text	Accessible - See Text
'Z' Intensity Modulation Input	Yes	Yes	Yes	Yes
Size H" x W" x D"	14-1/8 x 8-5/8 x 16	14-1/8 x 8-5/8 x 16	14-1/8 x 8-5/8 x 16	14-1/8 x 8-5/8 x 16
Shipping (Net) Weight - lb.	26 (18-1/2)	27 (20-1/2)	21 (20-1/2)	21 (20-1/2)
Price US\$	\$59.50	\$69.50	\$69.50	\$64.95
<b>COLOR KEY:</b>	From manual specs.	From flyer ads	From scope photos or schematic	

Table IV: Heathkit O-5 through O-8 Specifications

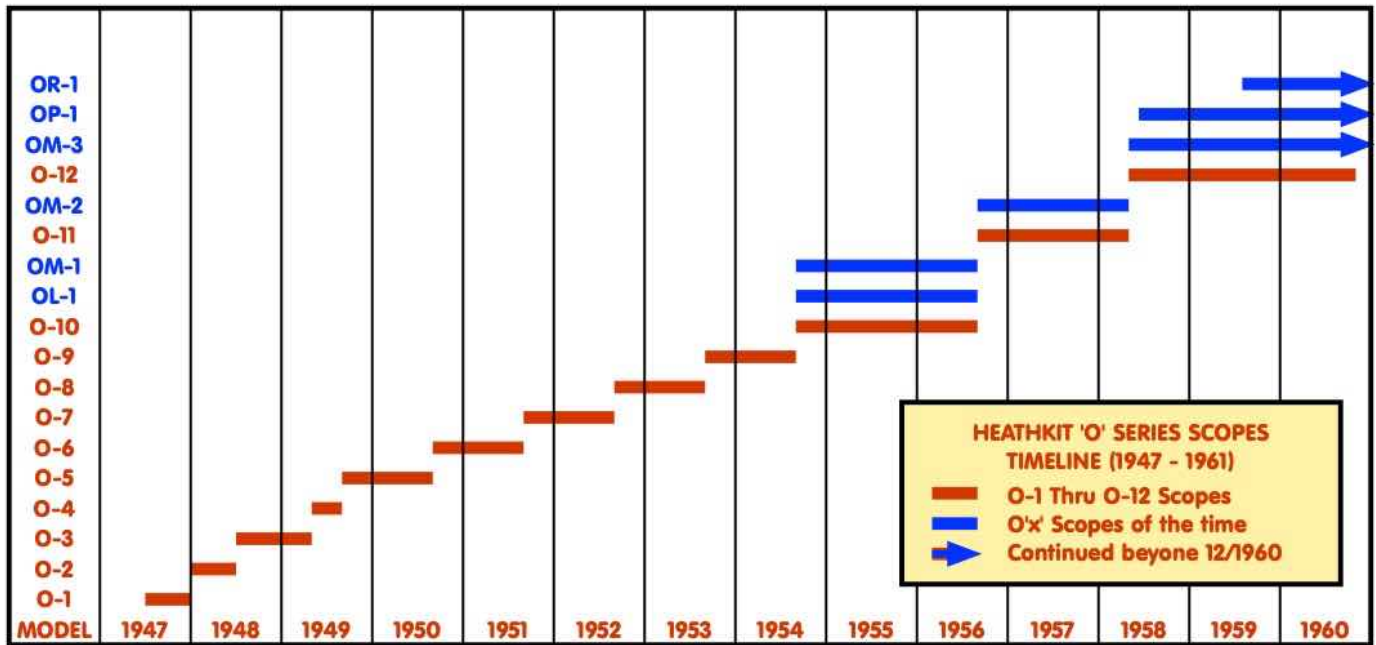

**Table V:** A timeline of Heathkit 'O' series scopes as well as other scopes offered at the time.

**Table IV** sums up the specifications for the last four 'O' series oscilloscopes, and **Table V** is a timeline of the twelve 'O'-series scopes and includes the other scopes that Heathkit offered between its epoch and the end of 1960.

**Author Comments:**

This has been an interesting series to write on. Heathkit was growing up during this period and these kits are a history of that. I have an O-12 and an OL-1 scope that I plan to restore. Many replacement parts are in-house so I just need the time to get working on them. In the cue is also a Heathkit AR-3, and SW-717 shortwave receiver, and a lot of non Heathkit electronics.

In the next few months I'll be writing on some smaller kits so the articles will be shorter, and maybe I'll have time to work on some of the projects too. Next month I plan to cover the GW-31. A handheld transceiver. I had a pair of them back in the very early sixties.

73, from AF6C



**Notes:**

1 The first two articles may be found here:  
[http://www.w6ze.org/Heathkit/Heathkit\\_085\\_O1\\_O4%20Scopes.pdf](http://www.w6ze.org/Heathkit/Heathkit_085_O1_O4%20Scopes.pdf)  
[http://www.w6ze.org/Heathkit/Heathkit\\_087\\_O5\\_O8%20Scopes.pdf](http://www.w6ze.org/Heathkit/Heathkit_087_O5_O8%20Scopes.pdf)

2 **Radio News** began in July of 1919 as **Radio Amateur News**. In July of 1920 the word 'Amateur' was dropped. and in August of 1948 **Radio News** became **Radio & Television News**. In April of 1957 it was shortened to **Radio & TV News**. In May of 1959 the name was changed to **Electronics World** which remained in publication through 1971. In January of 1972 it merged with **Popular Electronics**.

2 Later, O-10 thru O-12 scopes may use 5UP1 CRTs from other prominent manufacturers (Sylvania, Philips, and others)

4 See Chuck Penson - WATZZE's book **Heathkit Test Equipment Products** for a description of the various test equipment styles starting on page iv.

5 Schematics and parts lists for the 'O' series scopes may be found online at: [http://www.w6ze.org/Heathkit/Sch/O\\_scopes.html](http://www.w6ze.org/Heathkit/Sch/O_scopes.html)

*This article originally appeared in the December 2019 issue of RF, the newsletter of The Orange County Amateur Radio Club - W6ZE.*

*Remember, if you are getting rid of any old Heathkit Manuals or Catalogs, please pass them along to me for my research.*

*Thanks - AF6C*